

SEMPRE Farby Sp. z.o.o.

ul. Gen. J. Kuźstrowia 60
43-301 Bielsko-Biała
Poland

Tel: +48 (33) 496 06 09 Fax: +48 (33) 496 06 10

e-mail: info@semprefarby.pl

website: www.semprefarby.pl



Agrément Certificate

14/5159

Product Sheet 1

SEMPRETherm EXTERNAL WALL INSULATION SYSTEMS

SEMPRETherm EPS EXTERNAL WALL INSULATION BONDED SYSTEM

This Agrément Certificate Product Sheet⁽¹⁾ relates to the SempreTherm EPS External Wall Insulation Bonded System, comprising white or grey EPS insulation boards, adhesively fixed with supplementary mechanical fixings, with a reinforced basecoat and render finishes. It is suitable for use on the outside of external masonry walls in new and existing domestic and non-domestic buildings up to 18 metres in height.

(1) Hereinafter referred to as 'Certificate'.

CERTIFICATION INCLUDES:

- factors relating to compliance with Building Regulations where applicable
- factors relating to additional non-regulatory information where applicable
- independently verified technical specification
- assessment criteria and technical investigations
- design considerations
- installation guidance
- regular surveillance of production
- formal three-yearly review.

KEY FACTORS ASSESSED

Thermal performance — the system can be used to improve the thermal performance of external walls, and can contribute to satisfying the requirements of the national Building Regulations (see section 6).

Strength and stability — the system can adequately resist wind loads and has sufficient resistance to impact damage. The impact resistance is dependent on the finish chosen (see section 7).

Behaviour in relation to fire — the system has a B-s1, d0 reaction to fire classification in accordance with BS EN 13501-1 : 2018 (see section 8).

Risk of condensation — the system can contribute to limiting the risk of interstitial and surface condensation (see section 11).

Durability — when installed and maintained in accordance with the Certificate holder's recommendations and the terms of this Certificate, the system will remain effective for at least 30 years (see section 13).

The BBA has awarded this Certificate to the company named above for the system described herein. This system has been assessed by the BBA as being fit for its intended use provided it is installed, used and maintained as set out in this Certificate.

On behalf of the British Board of Agrément

Claire Curtis-Thomas

Date of Second issue: 15 May 2019

John Albon
Chief Scientific Officer

Claire Curtis-Thomas
Chief Executive

Originally certificated on 12 September 2014

The BBA is a UKAS accredited certification body – Number 113.

*The schedule of the current scope of accreditation for product certification is available in pdf format via the UKAS link on the BBA website at www.bbacerts.co.uk
Readers are advised to check the validity and latest issue number of this Agrément Certificate by either referring to the BBA website or contacting the BBA direct.*

Any photographs are for illustrative purposes only, do not constitute advice and should not be relied upon.

British Board of Agrément

Bucknalls Lane
Watford
Herts WD25 9BA

©2019

tel: 01923 665300
clientservices@bbacerts.co.uk
www.bbacerts.co.uk



Regulations

In the opinion of the BBA, the SempreTherm EPS External Wall Insulation Bonded System, if installed, used and maintained in accordance with this Certificate, can satisfy or contribute to satisfying the relevant requirements of the following Building Regulations (the presence of a UK map indicates that the subject is related to the Building Regulations in the region or regions of the UK depicted):



The Building Regulations 2010 (England and Wales) (as amended)

Requirement:	A1	Loading
Comment:		The system can sustain and transmit wind loads to the substrate wall. See sections 7.1 to 7.12 of this Certificate.
Requirement:	B4(1)	External fire spread
Comment:		The system can satisfy this Requirement. See sections 8.1 to 8.4 of this Certificate.
Requirement:	C2(b)	Resistance to moisture
Comment:		The system provides a degree of protection against rain ingress. See section 10.1 of this Certificate.
Requirement:	C2(c)	Resistance to moisture
Comment:		The system can contribute to minimising the risk of interstitial and surface condensation. See sections 11.1, 11.2 and 11.4 of this Certificate.
Requirement:	L1(a)(i)	Conservation of fuel and power
Comment:		The system can contribute to satisfying this Requirement. See sections 6.2 and 6.3 of this Certificate.
Regulation:	7	Materials and workmanship (applicable to Wales only)
Regulation:	7(1)	Materials and workmanship (applicable to England only)
Comment:		The system is acceptable. See section 13.1 and the <i>Installation</i> part of this Certificate.
Regulation:	7(2)	Materials and workmanship (applicable to England only)
Comment:		The system is restricted by this Regulation. See sections 8.1 to 8.4 of this Certificate.
Regulation:	26	CO₂ emission rates for new buildings
Regulation:	26A	Fabric energy efficiency rates for new buildings (applicable to England only)
Regulation:	26A	Primary energy consumption rates for new buildings (applicable to Wales only)
Regulation:	26B	Fabric performance values for new dwellings (applicable to Wales only)
Comment:		The system can contribute to satisfying these Regulations; however, compensatory fabric / services measures may need to be taken. See sections 6.2 and 6.3 of this Certificate.



The Building (Scotland) Regulations 2004 (as amended)

Regulation:	8(1)(2)	Durability, workmanship and fitness of materials
Comment:		The system can contribute to satisfying this Regulation. See sections 12.1 and 13.1 and the <i>Installation</i> part of this Certificate.
Regulation:	9	Building standards applicable to construction
Standard:	1.1	Structure
Comment:		The system can sustain and transmit wind loads to the substrate wall. See sections 7.1 to 7.12 of this Certificate.
Standard:	2.6	Spread to neighbouring buildings
Comment:		The system can satisfy this Standard, with reference to clauses 2.6.4 ⁽¹⁾⁽²⁾ , 2.6.5 ⁽¹⁾ and 2.6.6 ⁽²⁾ . See sections 8.1 to 8.6 of this Certificate.

Standard:	2.7	Spread on external walls
Comment:		The system can satisfy this Standard, and is acceptable for use more than one metre from a boundary, with reference to clauses 2.7.1 ⁽¹⁾⁽²⁾ , 2.7.2 ⁽²⁾ and Annex 2B ⁽¹⁾ . See sections 8.1 to 8.6 of this Certificate.
Standard:	3.10	Precipitation
Comment:		The system can contribute to satisfying this Standard, with reference to clauses 3.10.1 ⁽¹⁾⁽²⁾ and 3.10.2 ⁽¹⁾⁽²⁾ . See section 10.1 of this Certificate.
Standard:	3.15	Condensation
Comment:		The system can contribute to satisfying this Standard, with reference to clauses 3.15.1 ⁽¹⁾⁽²⁾ , 3.15.4 ⁽¹⁾⁽²⁾ and 3.15.5 ⁽¹⁾⁽²⁾ . See sections 11.3 and 11.4 of this Certificate.
Standard:	6.1(b)	Carbon dioxide emissions
Standard:	6.2	Building insulation envelope
Comment:		The system can contribute to satisfying these Standards, with reference to clauses (or parts of) 6.1.1 ⁽¹⁾ , 6.1.2 ⁽¹⁾⁽²⁾ , 6.1.3 ⁽¹⁾⁽²⁾ , 6.1.6 ⁽¹⁾ , 6.1.10 ⁽²⁾ , 6.2.1 ⁽¹⁾⁽²⁾ , 6.2.3 ⁽¹⁾ , 6.2.4 ⁽²⁾ , 6.2.5 ⁽²⁾ , 6.2.6 ⁽¹⁾ , 6.2.7 ⁽¹⁾ , 6.2.8 ⁽²⁾ , 6.2.9 ⁽¹⁾⁽²⁾ , 6.2.10 ⁽¹⁾ , 6.2.11 ⁽¹⁾ , 6.2.12 ⁽²⁾ and 6.2.13 ⁽¹⁾⁽²⁾ . See sections 6.2 and 6.3 of this Certificate.
Standard:	7.1(a)(b)	Statement of sustainability
Comment:		The system can contribute to satisfying the relevant requirements of Regulation 9, Standards 1 to 6, and therefore will contribute to a construction meeting the bronze level of sustainability as defined in this Standard. In addition, the system can contribute to a construction meeting a higher level of sustainability as defined in this Standard with reference to clauses 7.1.4 ⁽¹⁾⁽²⁾ [Aspect 1 ⁽¹⁾⁽²⁾ and 2 ⁽¹⁾], 7.1.6 ⁽¹⁾⁽²⁾ [Aspect 1 ⁽¹⁾⁽²⁾ and 2 ⁽¹⁾] and 7.1.7 ⁽¹⁾⁽²⁾ [Aspect 1 ⁽¹⁾⁽²⁾]. See section 6.2 of this Certificate.
Regulation:	12	Building standards applicable to conversions
Comment		All comments given for the system under Regulation 9, Standards 1 to 6, also apply to this Regulation, with reference to clause 0.12.1 ⁽¹⁾⁽²⁾ and Schedule 6 ⁽¹⁾⁽²⁾ .

(1) Technical Handbook (Domestic).

(2) Technical Handbook (Non-Domestic).



The Building Regulations (Northern Ireland) 2012 (as amended)

Regulation:	23	Fitness of materials and workmanship
Comment:		The system is acceptable. See section 13.1 and the <i>Installation</i> part of this Certificate.
Regulation:	28(b)	Resistance to moisture and weather
Comment:		Walls insulated with the system can satisfy this Regulation. See section 10.1 of this Certificate.
Regulation:	29	Condensation
Comment:		Walls insulated with the system can satisfy the requirements of this Regulation. See section 11.4 of this Certificate.
Regulation:	30	Stability
Comment:		The system can sustain and transmit wind loads to the substrate wall. See sections 7.1 to 7.12 of this Certificate.
Regulation:	36(a)	External fire spread
Comment:		The system can satisfy this Regulation. See sections 8.1 to 8.4 of this Certificate.
Regulation:	39(a)(i)	Conservation measures
		The system can contribute to satisfying this Regulation. See sections 6.2 and 6.3 of this Certificate.

Regulation:	40	Target carbon dioxide emission rate
Comment:		The system can contribute to satisfying this Regulation. See sections 6.2 and 6.3 of this Certificate.

Construction (Design and Management) Regulations 2015 Construction (Design and Management) Regulations (Northern Ireland) 2016

Information in this Certificate may assist the client, designer (including Principal Designer) and contractor (including Principal Contractor) to address their obligations under these Regulations.

See section: *3 Delivery and site handling (3.2 and 3.4)* of this Certificate.

Additional Information

NHBC Standards 2019

In the opinion of the BBA, the SempreTherm EPS External Wall Insulation Bonded System, if installed, used and maintained in accordance with this Certificate, can satisfy or contribute to satisfying the relevant requirements in relation to *NHBC Standards⁽¹⁾, Part 6 Superstructure (excluding roofs), Chapter 6.9 Curtain walling and cladding.*

(1) There is a general requirement in NHBC Standards Chapter 6.9 for fire-retardant-treated EPS insulation to be used with this system in accordance with BS EN 13163 : 2012.

Technical Specification

1 Description

1.1 The SempreTherm EPS External Wall Insulation Bonded System comprises white or grey expanded polystyrene (EPS) insulation boards, reinforced basecoat, primer and render finishes, for application onto the external walls of masonry construction (see Figure 1).

1.2 The insulation boards are adhesively fixed direct to the substrate wall with a minimum 40% coverage of the board. Supplementary mechanical fixings are applied through the insulation boards whilst the adhesive is setting. The first layer of basecoat is then applied to the surface of the boards to a uniform thickness before a single layer of reinforcing mesh is applied and immediately embedded, and the surface smoothed with a trowel. An additional layer of basecoat is applied, over the reinforced basecoat, to achieve the required thickness. The system is left to dry for a minimum of three days before the primer is applied, followed by the finishing coat (see sections 1.3 and 16 *Installation*, which describes the installation method in more detail).

1.3 The system comprises the following components:

Adhesives

- Sempre Start TS-100 — a cementitious powder requiring the addition of clean water (approximately 0.2 to 0.22 litre.kg⁻¹) and mixed with a high-speed mixer for 3 to 5 minutes
- Sempre Universal TU-200 — a cementitious powder requiring the addition of clean water (approximately 0.22 to 0.24 litre.kg⁻¹) and mixed with a high-speed mixer for 3 to 5 minutes

Insulation⁽¹⁾

- SempreTherm white expanded polystyrene (EPS 70) insulation boards — 1200 by 600 mm or 1000 by 500 mm, in a range of thicknesses between 50⁽²⁾ and 150 mm in 10 mm increments, with a nominal density of 15 kg·m⁻³, a minimum compressive strength of 70 kPa and a nominal tensile strength perpendicular to the face of 100 kPa. It is manufactured to comply with BS EN 13163 : 2012
- SempreTherm grey expanded polystyrene (EPS 70) insulation boards — 1200 by 600 mm or 1000 by 500 mm, in a range of thicknesses between 50 and 150 mm in 10 mm increments, with a nominal density of 15 to 17 kg·m⁻³, a

minimum compressive strength of 70 kPa and a nominal tensile strength perpendicular to the face of 100 kPa. It is manufactured to comply with BS EN 13163 : 2012

- (1) For declared thermal conductivity values (λ_D), see Table 2.
(2) Insulation thicknesses of 50 mm would generally be used in reveals.

Mechanical fixings (supplementary)

Anchors with adequate length to suit the substrate and the insulation thickness, approved and supplied by the Certificate holder as follows:

- Ejotherm NT U⁽¹⁾ – high-density polyethylene (HDPE) anchor sleeve with galvanized steel centre pin

(1) Other fixings may be used provided they can be demonstrated to have equal or higher pull-out, plate diameter and plate stiffness characteristics.

Basecoat

- Sempre Universal TU-200 — a cementitious powder requiring the addition of clean water (0.22 to 0.24 litre.kg⁻¹) and mixed with a high-speed mixer for 3 to 5 minutes. Applied to a nominal thickness of 5 mm

Reinforcement

- Sempre TG-15 Fibreglass Mesh — an alkali-resistant, glass fibre mesh, with a mass per unit area of approximately 165 g.m⁻² and a mesh size of approximately 4.0 by 4.0 mm
- Sempre TG-16 Fibreglass Mesh — an alkali-resistant, glass fibre mesh, with a mass per unit area of approximately 230 g.m⁻² and a mesh size of approximately 7.0 by 7.0 mm

Primers

- Sempre Tesoro Grunt — a ready-to-use pigmented liquid for use on highly absorbent masonry and concrete substrates prior to the application of adhesive and basecoat
- Sempre Maresil Grunt — a polysilicate primer used with Sempre Maresil Tynk

Finishing coats⁽¹⁾

- Sempre Tesoro Tynk — an acrylate-based ready-to-use paste, applied to the primed basecoat. Available in particle sizes of 1.5, 2, 2.5 and 3 mm, with a coverage rate of 2.3, 3.0, 3.7 and 4.5 kg.m⁻³ respectively
- Sempre Maresil Tynk — a polysilicate-based ready-to-use paste, applied to the primed basecoat. Available in particle sizes of 1.5, 2, 2.5 and 3 mm, with a coverage rate of 2.3, 3.0, 3.7 and 4.5 kg.m⁻³ respectively.

(1) The thickness of the applied finish is controlled by the particle size specified.

Figure 1 SempreTherm EPS External Wall Insulation Bonded System

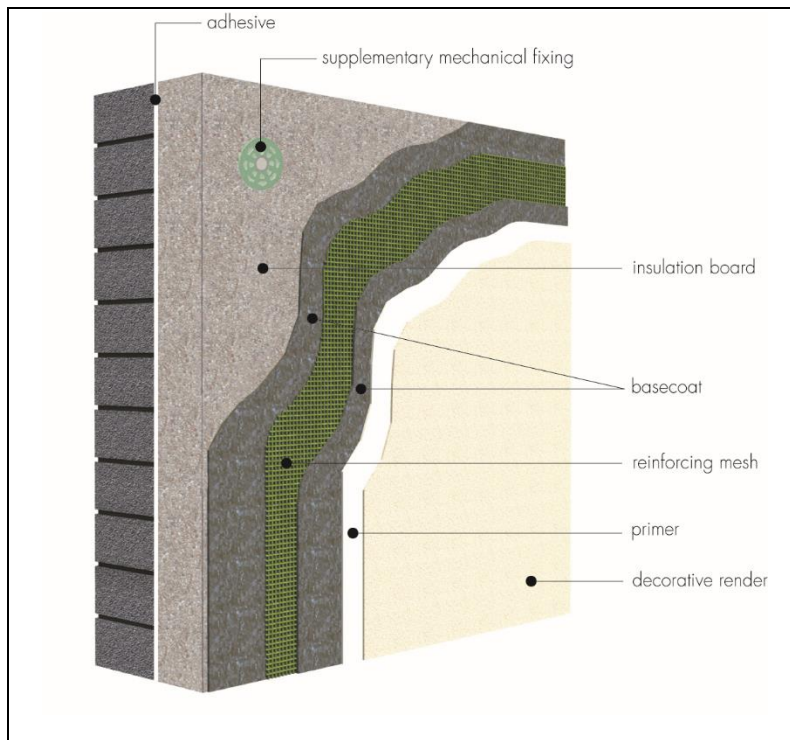

1.4 Ancillary materials also used with the system:

- range of aluminium, PVC-U or stainless steel profiles, comprising:
 - base profiles (starter track)
 - edge profiles — PVC corner bead with mesh, and drip beads
 - corner profiles with optional PVC-U nosing
 - render stop profiles (stop bead with mesh)
 - movement joints (V and E version)
 - profile connectors and fixings.

1.5 Ancillary materials also used with the system but outside the scope of this Certificate:

- expansion joints
- PVC clip-on starter track beads
- window frame seal beads
- aluminium insulated window sills with PVC end caps
- flashings
- spiral fixings
- fungicidal wash
- algae remover
- silicone sealants in accordance with BS EN ISO 11600 : 2003
- expansion foam (fire-rated polyurethane foam used for filling gaps between insulation boards)
- sealers.

2 Manufacture

2.1 Components are manufactured by the Certificate holder or bought in from suppliers, to an agreed specification.

2.2 As part of the assessment and ongoing surveillance of product quality, the BBA has:

- agreed with the manufacturer the quality control procedures and product testing to be undertaken
- assessed and agreed the quality control operated over batches of incoming materials

- monitored the production process and verified that it is in accordance with the documented process
- evaluated the process for management of nonconformities
- checked that equipment has been properly tested and calibrated
- undertaken to carry out the above measures on a regular basis through a surveillance process, to verify that the specifications and quality control operated by the manufacturer are being maintained.

3 Delivery and site handling

3.1 The insulation boards are delivered to site shrink-wrapped in polythene packs bearing the manufacturer's and product identification marks and batch numbers.

3.2 The other components are delivered to site in the packaging and quantities listed in Table 1. Each package carries the manufacturer's and product identification marks and batch numbers.

Table 1 Component supply details

Component	Quantity and package
Sempre Start TS-100 — adhesive	25 kg bags
Sempre Universal TU-200 — adhesive/basecoat	25 kg bags
SempreTherm (white and grey) EPS	Shrink-wrapped in polyethylene
Mechanical fixings (supplementary)	Boxed by manufacturer
Sempre TG-15 Fibreglass Mesh	1 m width x 50 m length rolls
Sempre TG-16 Fibreglass Mesh	1 m width x 50 m length rolls
Sempre Tesoro Grunt — primer/keycoat	10 litre tubs
Sempre Maresil Grunt — primer/keycoat	10 litre tubs
Sempre Tesoro Tynk — finish coat	25 kg tubs
Sempre Maresil Tynk — finish coat	25 kg tubs

3.3 The insulation boards must be stored on a firm, clean and level base, off the ground and under cover until required for use. Care must be taken during handling to avoid damage.

3.4 The boards must be protected from prolonged exposure to sunlight, either by storing opened packs under cover or re-covering with opaque polyethylene sheeting. Care must be taken to avoid contact with solvents or materials containing volatile organic components. The boards must not be exposed to open flame or other ignition sources.

3.5 The adhesive, basecoat and topcoats and all cementitious materials must be stored in dry conditions at temperatures between 5 and 30°C, off the ground and protected from moisture. Contaminated material must be discarded.

3.6 The primers should be stored in a safe area, under cover and protected from excessive heat and frost at all times.

Assessment and Technical Investigations

The following is a summary of the assessment and technical investigations carried out on the SempreTherm EPS External Wall Insulation Bonded System.

Design Considerations

4 General

4.1 The SempreTherm EPS External Wall Insulation Bonded System, when installed in accordance with this Certificate, is satisfactory for use in reducing the thermal transmittance (U value) of external masonry or concrete walls of new and existing buildings. It is essential that the detailing techniques specified in this Certificate are carried out to a high standard if the ingress of water into the insulation is to be avoided and the full thermal benefit obtained from treatment with the system (eg the insulation must be protected by an overhang, and window sills should be designed and installed so as to direct water away from the building).

4.2 For improved thermal/carbon-emissions performance of the structure, the designer should consider additional/alternative fabric and/or services measures.

4.3 The system is for application to the outside of external walls of masonry, normal weight concrete, lightweight concrete, autoclaved concrete or no-fines concrete construction, on new or existing domestic and non-domestic buildings (with or without existing render) up to 18 metres in height. Prior to the installation of the system, wall surfaces should comply with section 14 of this Certificate.

4.4 New walls subject to the national Building Regulations should be constructed in accordance with the relevant recommendations of:

- BS EN 1992-1-1 : 2004 and its UK National Annex
- BS EN 1996-1-1 : 2005 and its UK National Annex
- BS EN 1996-2 : 2006 and its UK National Annex
- BS 8000-2.2 : 1990
- BS 8000-0 : 2014
- BS 8000-3 : 2001.

4.5 New walls not subject to regulatory requirements should also be built in accordance with the Standards identified in section 4.4 of this Certificate.

4.6 Movement joints should be incorporated into the system in line with existing movement joints in the building structure and in accordance with the Certificate holder's recommendations for the specific installation.

4.7 The system will improve the weather resistance of a wall and provide a decorative finish. However, for existing buildings, it should only be installed where there are no signs of dampness on the inner surface of the wall other than those caused solely by condensation.

4.8 The effect of the system on the acoustic performance of a construction is outside the scope of this Certificate.

4.9 The fixing of sanitary pipework, plumbing, rainwater goods, satellite dishes, clothes lines, hanging baskets and similar items to the system is outside the scope of this Certificate. See section 4.10 of this Certificate.

4.10 External pipework and ducts should be removed before installation, and alterations made to underground drainage to accommodate repositioning of the pipework to the finished face of the system. The Certificate holder can advise on suitable fixing methods, but these are outside the scope of this Certificate.

4.11 The designer should select a construction appropriate to the local wind-driven rain index, paying due regard to the design detailing, workmanship and materials to be used.

4.12 It is essential that this system is installed and maintained in accordance with the conditions set out in this Certificate.

5 Practicability of installation

The system should only be installed by specialised contractors who have successfully undergone training and registration by the Certificate holder (see section 15).

Note: The BBA operates a UKAS-accredited Approved Installer Scheme for external wall insulation; details of approved installer companies are included on the BBA's website (www.bbacerts.co.uk).

6 Thermal performance

6.1 Calculations of thermal transmittance (U value) should be carried out in accordance with BS EN ISO 6946 : 2017 and BRE Report BR 443 : 2006, using the declared thermal conductivities values (λ_D) of the insulations given in Table 2.

Table 2 Declared thermal conductivity values (λ_D) and available thicknesses

Insulation types	Thickness (mm)	Thermal conductivity ($W \cdot m^{-1} \cdot K^{-1}$)
White EPS 70	50 to 150	0.038
Grey EPS 70		0.031



6.2 The U value of a completed wall will depend on the selected insulation type and thickness, fixing method and type of fixing, and the insulating value of the substrate masonry and its internal finish. Calculated U values for sample construction in accordance with the national Building Regulations are given in Table 3, and are based on the thermal conductivities given in Table 2.

Table 3 Insulation thickness required to achieve design U values⁽¹⁾⁽²⁾⁽³⁾

U value ⁽⁴⁾ ($W \cdot m^{-2} \cdot K^{-1}$)	Thickness of insulation (mm)			
	215 mm brickwork, $\lambda = 0.56 W \cdot m^{-1} \cdot K^{-1}$		200 mm dense blockwork, $\lambda = 1.75 W \cdot m^{-1} \cdot K^{-1}$	
	White EPS 70	Grey EPS 70	White EPS 70	Grey EPS 70
0.18	— ⁽⁵⁾	— ⁽⁵⁾	— ⁽⁵⁾	— ⁽⁵⁾
0.19	— ⁽⁵⁾	150	— ⁽⁵⁾	— ⁽⁵⁾
0.25	130	110	140	120
0.26	130	100	140	110
0.28	120	100	130	100
0.30	110	90	120	100
0.35	90	80	100	80

- (1) Wall construction inclusive of 13 mm plaster ($\lambda = 0.57 W \cdot m^{-1} \cdot K^{-1}$), brickwork (protected) with 17.1% mortar or dense blockwork with 6.7% mortar ($\lambda = 0.88 W \cdot m^{-1} \cdot K^{-1}$). A 5 mm thick adhesive layer ($\lambda = 0.43 W \cdot m^{-1} \cdot K^{-1}$) covering 40% of the area is also included and a board emissivity of 0.9, together with an external render thickness of 5 mm ($\lambda = 1 W \cdot m^{-1} \cdot K^{-1}$).
- (2) Calculations based on a bonded system that included 3 galvanized steel fixings per square metre with 8 mm diameter sleeve and with a point thermal transmittance (X_p) of $0.004 W \cdot K^{-1}$ per pin. Use of other types of fixings should be calculated in accordance with BS EN ISO 6946 : 2017. A gap correction ($\Delta U''$) of zero is assumed.
- (3) Based upon incremental insulation thickness of 10 mm.
- (4) U value calculations based on 3 galvanized steel fixings per m^2 on the main section of the wall. However, an increased number of fixings on the edge zone would result in slightly higher U values.
- (5) See section 4.2 of this Certificate.

6.3 Care must be taken in the overall design and construction of junctions with other elements and openings to minimise thermal bridges and air infiltration. Detailed guidance can be found in the documents supporting the national Building Regulations.

7 Strength and stability

General



7.1 The Certificate holder is ultimately responsible for the design of the system and it is the responsibility of the company installing the system to accurately follow the installation instructions (see also section 5 of this Certificate). The Certificate holder must also verify that a suitably experienced and qualified individual (with adequate professional indemnity) establishes that:

- the wind loads on the different zones of the building's elevation for the specific geographical location have been calculated correctly (see section 7.3)
- the system can adequately resist and safely transfer the calculated loads, accounting for all possible failure modes, to the substrate wall and supporting structure (see sections 7.3 to 7.6).

7.2 The substrate and supporting structure must be capable of transferring all additional loading due to the installation of the system to the ground in a satisfactory manner. The adequacy of the substrate and supporting structure must be verified by the person or party responsible for the global stability of the building to which the system is applied. Any defects should be made good prior to the system being installed.

7.3 The wind loads on the walls should be calculated, taking into account all relevant factors such as location and topography, in accordance with BS EN 1991-1-4 : 2005 and its UK National Annex. All of the factors affecting wind load on each elevation and specific zones of the building must be considered. In accordance with BS EN 1990 : 2002

and its UK National Annex, a partial factor of 1.5 must be applied to the calculated characteristic wind pressure values to establish the design wind load to be resisted by the system.

7.4 Installations correctly designed in accordance with this Certificate will safely accommodate the applied loads due to the self-weight of the system, wind and impact.

7.5 Positive wind load is transferred to the substrate wall directly via compression through the render and insulation system.

7.6 Negative wind load is transferred to the substrate wall via⁽¹⁾⁽²⁾:

- the bond between the insulation and render system (see section 7.7)
- the tensile strength of the insulation (see section 7.8)
- the bond between the adhesive and the insulation interface⁽³⁾ (see section 7.9)
- the bond between the substrate and adhesive interface⁽³⁾ (see section 7.10).

(1) For adhesively fixed systems with supplementary mechanical fixings, the contribution of the fixings is not considered when calculating resistance to wind load.

(2) Further guidance is given in BBA Guidance Note 1, available on the BBA website (www.bbacerts.co.uk).

(3) The percentage of adhesive coverage should be considered.

7.7 The characteristic bond resistance between the insulation and render interface derived from test results was 80 kN.m^{-2} . The design resistance of the bond between the insulation and render (N_{RD1}) should be taken as the characteristic bond resistance divided by a partial factor of 9.

7.8 The characteristic tensile resistance of the insulation material may be taken as 100 kN.m^{-2} and should be divided by a partial material factor of 2.5 to establish the ultimate design resistance of the insulation ($R_{d,ins}$).

7.9 The characteristic bond resistance between the adhesive and the insulation derived from test results was $80 \text{ kN.m}^{-2(1)}$. The design resistance of the bond between the adhesive and insulation (N_{RD2}) should be taken as this value divided by a partial factor of 9.

(1) The minimum bonded surface area (A_{min}) should not be less than 40%.

7.10 The characteristic bond resistance between the substrate and the adhesive derived from test results was $80 \text{ kN.m}^{-2(1)(2)(3)}$. The design resistance of the bond between the substrate and the adhesive (N_{RD3}) should be taken as the characteristic resistance divided by a partial factor of 9.

(1) The bond between the substrate and the adhesive from the test should have a minimum failure resistance of 250 kN.m^{-2} after the adhesive has fully cured and in dry conditions, in accordance with ETAG 004 : 2013. The minimum failure resistance value is based on a minimum 28 day curing time of the test sample.

(2) The results from tests carried out on site for the bond (while the adhesive is curing) between the substrate and the adhesive should be at least equal to 80 kN.m^{-2} .

(3) The minimum bonded surface area (A_{min}) should not be less than 40%.

7.11 The number and spacing of the supplementary fixings should be determined by the Certificate holder. Provided the substrate wall is suitable and the supplementary fixings are covered by an appropriate ETA, the fixings will initially transfer the weight of the insulation system to the substrate wall while the adhesive is curing. However, since the characteristic pull-out resistance values are dependent on the substrate type, the fixing must be selected to suit the specific loads and substrate⁽¹⁾.

(1) To qualify as suitable data, the age and condition of the substrate must be equivalent to that used to establish the values in the ETA. If this is not the case, site-specific pull out tests must be carried out.

7.12 The data obtained from sections 7.7 to 7.10 must be assessed against the design wind load and the following expression must be satisfied⁽¹⁾⁽²⁾:

For safe design:

$$R_d \geq W_e$$

$$R_{d,b,ins/render} = A_r * N_{RD1}$$

$$R_{d,t,ins} = \text{characteristic tensile strength of insulation}/2.5$$

$$R_{d,b,adh/ins} = A_{min} * N_{RD2}$$

$$R_{d,b,sub/adh} = A_{min} * N_{RD3}$$

Where:

- R_d** is the design ultimate resistance (kN·m⁻²) taken as the minimum of **R_{d,b,ins/rend}**, **R_{d,t,ins}**, **R_{d,b,adh/ins}** and **R_{d,b,sub/adh}**
- W_e** is the maximum design wind load (kN·m⁻²)
- R_{d,b,ins/rend}** is the bond design resistance between the insulation and render (kN·m⁻²)
- A_r** is the reinforced basecoat bond area (based on % area covered)
- N_{RD1}** is the design adhesive bond resistance between the insulation and render based on tests (kN·m⁻²)
- R_{d,b,adh/ins}** is the bond design resistance between the insulation and adhesive (kN·m⁻²)
- A_{min}** is the minimum bonded surface area (based on % area covered)
- N_{RD2}** is the design bond resistance between insulation and adhesive based on tests (kN·m⁻²)
- R_{d,b,sub/adh}** is the design bond resistance between the substrate and adhesive (kN·m⁻²)
- N_{RD3}** is the design bond resistance between the substrate and adhesive based on tests (kN·m⁻²)

- (1) If the minimum design resistance (R_d) calculated in 7.7 to 7.10 is less than the design wind pressure, the bonded surface area (A_{min}) should be increased.
- (2) If the minimum bonded surface area required to resist the design wind load is higher than 100%, the system would need to be mechanically fixed and therefore should not be installed: mechanically fixed system requirements have not been assessed with this Certificate.

Impact resistance

7.13 Hard body impact tests were carried out in accordance with ETAG 004 : 2013. The system is suitable for use in the Categories up to and including those specified in Table 4 of this Certificate.

Table 4 System impact resistance

Rendering system: Sempre Universal TU-200 (basecoat) + finishing coats indicated below:	Use Category ⁽¹⁾	
	Single layer TG-15 mesh (see section 1.3)	Single layer TG-16 mesh (see section 1.3)
Sempre Tesoro Tynk (acrylate binder – particle size 1.5 mm)	Category I	—
Sempre Maresil Tynk (silicate-silicone binder – particle size 1.5 mm)	Category II	

(1) The use Categories are defined in ETAG 004 : 2013 as:

- Category I — a zone readily accessible at ground level to the public and vulnerable to hard body impacts but not subjected to abnormally rough use
- Category II — a zone liable to impacts from thrown or kicked objects, but in public locations where the height of the system will limit the size of the impact; or at lower levels where access to the building is primarily to those with some incentive to exercise care
- Category III — a zone not likely to be damaged by normal impacts caused by people or by thrown or kicked objects.

8 Behaviour in relation to fire



8.1 The reaction to fire classification⁽¹⁾ of the system in ‘white’ colour is class B-s1, d0 in accordance with BS EN 13501-1 : 2018.

(1) BRE global test report 268971, a copy is available from the Certificate holder on request.

8.2 The fire classification applies to the full range of insulation thicknesses covered by this Certificate (see section 1.3). The maximum organic content of the basecoat is 1.27% and finish coats is 8.08%.

8.3 The insulations in isolation are not classified as non-combustible or of limited combustibility, and the system is restricted for use in buildings up to 18 metres in height.

8.4 For houses in Scotland, and for all buildings in England and Wales and Northern Ireland, the system is considered suitable for use on, or at any distance from, the boundary.



8.5 For flats and maisonettes and non-domestic buildings in Scotland, the system is suitable only for use more than one metre from the boundary.

8.6 The system is not classified as 'non-combustible'; therefore, calculations for unprotected areas may apply dependent on the fire resistance characteristics of the wall.

8.7 For application to second storey walls and above, it is recommended that the designer considers at least one stainless steel fixing per square metre and fire barriers in line with compartment walls and floors as advised in BRE Report BR 135 : 2013 (see Figure 2 of this Certificate).

Figure 2 Fire barrier details

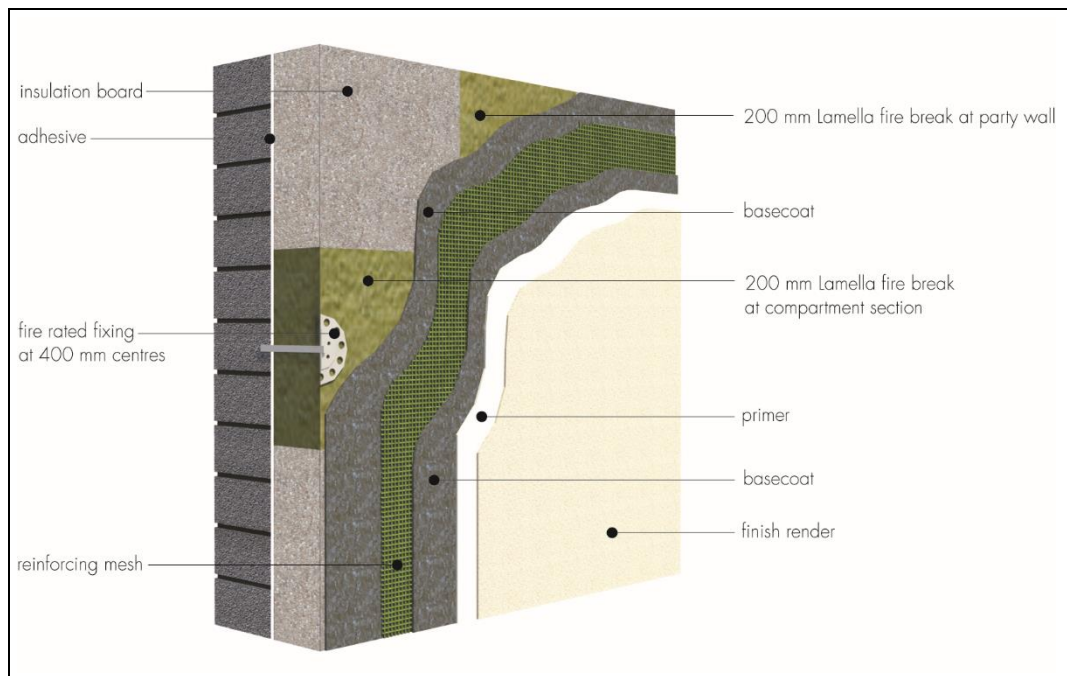

9 Proximity of flues and appliances

When the system is installed in close proximity to certain flue pipes, the relevant provisions of the national Building Regulations should be met:

England and Wales — Approved Document J

Scotland — Mandatory Standard 3.19, clause 3.19.4⁽¹⁾⁽²⁾

(1) Technical Handbook (Domestic).

(2) Technical Handbook (Non-Domestic).

Northern Ireland — Technical Booklet L.

10 Water resistance



10.1 The system will provide a degree of protection against water ingress. However, care should be taken to ensure that walls are adequately watertight prior to the application of the system. The system must only be installed where there is no sign of dampness on the inner surface of the substrate other than that caused solely by condensation.

10.2 Designers and installers should take particular care in detailing around openings, penetrations and movement joints to minimise the risk of water ingress.

10.3 The guidance given in BRE Report BR 262 : 2002 should be followed in connection with the watertightness of solid wall constructions. The designer should select a construction appropriate to the local wind-driven index, paying due regard to the design detailing, workmanship and materials to be used.

10.4 At the top of walls, the system should be protected by an adequate overhang or other detail designed for use with this type of system (see section 16).

11 Risk of condensation



11.1 Designers must ensure that an appropriate condensation risk analysis has been carried out for all parts of the construction, including openings and penetrations at junctions between the insulation system and windows, to minimise the risk of condensation. The recommendations of BS 5250 : 2011 should be followed.

Surface condensation



11.2 Walls will adequately limit the risk of surface condensation when the thermal transmittance (U value) does not exceed $0.7 \text{ W}\cdot\text{m}^{-2}\cdot\text{K}^{-1}$ at any point and the junctions with other elements and openings comply with section 6.3 of this Certificate.



11.3 Walls will adequately limit the risk of surface condensation when the thermal transmittance (U value) does not exceed $1.2 \text{ W}\cdot\text{m}^{-2}\cdot\text{K}^{-1}$ at any point. Guidance may be obtained from BS 5250 : 2011, Section 4 and Annex G, and BRE Report BR 262 : 2002.

Interstitial condensation



11.4 Walls incorporating the system will adequately limit the risk of interstitial condensation when they are designed and constructed in accordance with BS 5250 : 2011, Section 4 and Annexes D and G.

11.5 The water vapour resistance (μ) factor (for the insulation boards) and equivalent air layer thickness (S_d) (for the render systems) is shown in Table 5.

Table 5 Water vapour resistance factor and equivalent air layer thickness

	S_d (m)	μ
Expanded polystyrene (white/grey)	—	20 to 40 ⁽³⁾ (EPS 70)
Sempre Universal TU-200 ⁽¹⁾ (basecoat) + Sempre Tesoro Grunt (keycoat) + Sempre Tesoro Tynk (finish coat - particle size 1.5 mm) ⁽²⁾	0.65	—
Sempre Universal TU-200 ⁽¹⁾ (basecoat) + Sempre Tesoro Grunt (keycoat) + Sempre Tesoro Tynk (finish coat - particle size 3.0 mm) ⁽²⁾	0.93	—
Sempre Universal TU-200 ⁽¹⁾ (basecoat) + Sempre Maresil Grunt (keycoat) + Sempre Maresil Tynk (finish coat - particle size 3.0 mm) ⁽²⁾	0.22	—

(1) The basecoat is applied to a minimum thickness of 3.5 mm.

(2) Render system comprises basecoat, reinforcing mesh, key coat and finish coat (minimum thickness = 5 mm, which is based on particle size of 1.5 mm, and maximum thickness = 6.5 mm, which is based on particle size of 3 mm).

(3) It is recommended that the lower figure is used when assessing the interstitial condensation risk.

12 Maintenance and repair



12.1 An initial inspection should be made within 12 months and regularly thereafter to include:

- visual inspection of the render for signs of damage. Cracks in the render exceeding 0.2 mm must be repaired
- examination of the sealant around openings and service entry points
- visual inspection of architectural details designed to shed water to confirm that they are performing properly
- visual inspection to ensure that water is not leaking from external downpipes or gutters; such leakage could penetrate the rendering
- necessary repairs effected immediately and the sealant joints at window and door frames replaced at regular intervals
- maintenance schedules, which should include the replacement and resealing of joints (for example, between the insulation system and window and door frame).

12.2 Damaged areas must be repaired using the appropriate components and procedures detailed in the Certificate holder's installation instructions and in accordance with BS EN 13914-1 : 2016.

13 Durability



13.1 The system will have a service life of at least 30 years provided any damage to the surface finish is repaired immediately and regular maintenance is undertaken, as described in section 12 of this Certificate.

13.2 Any render containing Portland cement may be subject to lime bloom. The occurrence of this may be reduced by avoiding application in adverse weather conditions. The effect is transient and less noticeable on lighter colours.

13.3 The render may become discoloured with time, the rate depending on the initial colour, the degree of exposure and atmospheric pollution, as well as the design and detailing of the wall. In common with traditional renders, discoloration by algae and lichens may occur in wet areas. The appearance may be restored by a suitable power wash or, if required, by over coating.

13.4 To maintain a high-quality appearance, it may be necessary to periodically overcoat the building using a suitable masonry coating (ie one covered by a valid BBA Certificate for this purpose). Care should be taken not to adversely affect the water vapour transmission or fire characteristics of the system. The advice of the Certificate holder should be sought as to the suitability of a particular product.

Installation

14 Site survey and preliminary work

14.1 A pre-installation survey of the property must be carried out to determine suitability for treatment and the need for any necessary repairs to the building structure before application of the system. A specification is prepared for each elevation of the building indicating:

- the position of beads
- detailing around windows, doors and at eaves
- damp-proof course (dpc) level
- exact position of expansion joints, if required
- areas where flexible sealants must be used
- any alterations to external plumbing
- the position of fire barriers.

14.2 The survey should include tests conducted on the walls of the building by the Certificate holder or their approved installers to determine the bond strength between the adhesive and the substrate and be satisfied that the pull-out resistance of the proposed supplementary mechanical fixings from the substrate is adequate. An assessment and recommendation should be made on the minimum bond strength and type and number of fixings required to withstand the building's expected wind loading based on calculations using the test site data in accordance with section 7 of this Certificate.

14.3 All modifications, such as provision for fire barriers (see section 8) and necessary repairs to the building structure, must be completed before installation of the system commences.

14.4 Surfaces should be sound, clean and free from loose material. The flatness of surfaces must be checked; this may be achieved using a straight-edge tool spanning the storey height. Any excessive irregularities, ie greater than 20 mm, must be made good prior to installation, to ensure that the insulation boards are installed with a smooth, in-plane finished surface.

14.5 Where surfaces are covered with an existing rendering, it is essential that the bond between the background and the render is adequate. All loose areas should be hacked off and reinstated.

14.6 On existing buildings, purpose-made sills must be fitted to extend beyond the finished face of the system. New buildings should incorporate suitably deep sills.

14.7 Internal wet work, eg screed or plastering, should be completed and allowed to dry prior to the application of a system.

15 Approved installers

Application of the system, within the context of this Certificate, must be carried out by installers approved by the Certificate holder. A Certificate holder approved installer is a company:

- employing operatives who have been trained and approved by the Certificate holder to install the system and has operatives who, upon completion of their training, have been issued with an appropriate identification card by the Certificate holder
- which has undertaken to comply with the Certificate holder's application procedure, containing the requirement for each application team to include at least one member-operative trained by the Certificate holder
- subject to at least one inspection per annum by the Certificate holder to ensure suitable site practices are being employed. This may include unannounced site inspections.

16 Procedure

General

16.1 Installation of the system must be carried out in accordance with the Certificate holder's current installation instructions and this Certificate.

16.2 Weather conditions should be monitored to ensure correct application and curing conditions. Application of coating materials must not be carried out at temperatures below 5°C or above 30°C, or if exposure to frost is likely, and the coating must be protected from rapid drying. Installation should not take place during rainfall or if rain is anticipated. In addition, cementitious-based renders must not be applied if the temperature will fall below 0°C within 72 hours of completion.

16.3 The planarity of the substrate must be checked, and any protrusions exceeding 10 mm removed.

16.4 The primer should be used as required and appropriately selected for the type of finish coat used (see section 1.3)

16.5 All rendering should be in accordance with the relevant recommendations of BS EN 13914-1 : 2016.

16.6 Where required, a fungicidal wash is applied to the entire surface of the external wall by brush, roller or spray.

Positioning and securing insulation boards

16.7 The base profile is secured to the external wall above the dpc using the approved profile fixings at approximately 300 mm centres (see Figure 3). Base rail connectors are inserted at all rail joints. Extension profiles are fixed to the front lip of the base rail or stop end channel where appropriate.

Figure 3 Typical section of base profile

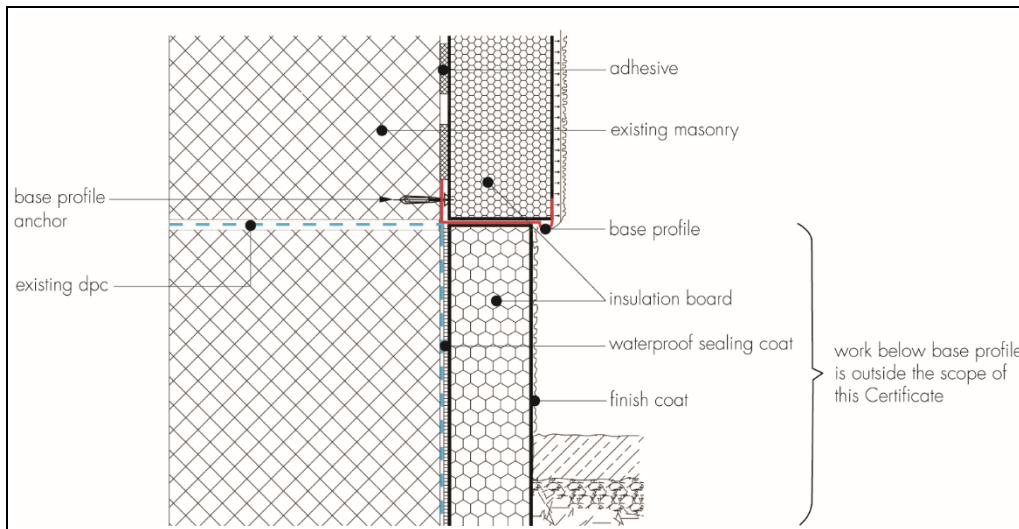

16.8 The adhesive is prepared with the required amount of clean water (see section 1.1) and mixed with a paddle mixer until the desired consistency is achieved. After allowing the adhesive to rest for 5 minutes, it is stirred again. The adhesive is applied in a continuous line around the perimeter of the board (at least 30 mm wide) with at least six additional dabs of adhesive (approximately 80 to 120 mm in diameter) distributed uniformly over the remaining surface, to achieve at least 40% coverage of the board. Alternatively, for even and smooth substrates, the whole insulation board can be coated with adhesive using a notched trowel to produce a coat 2 to 5 mm in thickness. The insulation board should be immediately placed on the substrate and pressed into place.

Figure 4 Insulation board adhesive pattern

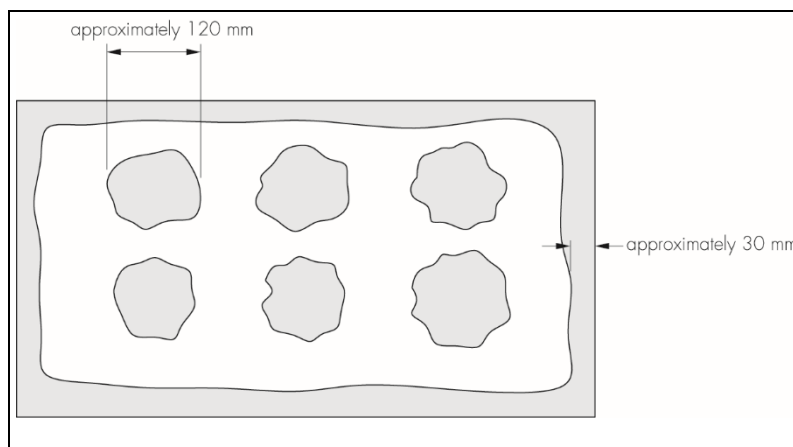

16.9 The first run of insulation boards is placed on the base profile. The boards must be pressed firmly against the wall and butted tightly together, and aligned to achieve a level finish. Subsequent rows of boards are positioned so that the vertical joints are staggered and overlapped at the building corners, ensuring joints do not occur within 200 mm of the corners of openings (see Figure 5). Joints greater than 2 mm must be filled with slivers of insulation or low density polyurethane foam. Gaps greater than 10 mm must be closed by repositioning or, where appropriate, by cutting boards to fit. Any high spots or irregularities are removed by lightly planing with a rasp over the whole surface. Alignment should be checked as work proceeds.

Figure 5 Typical arrangement of insulation boards

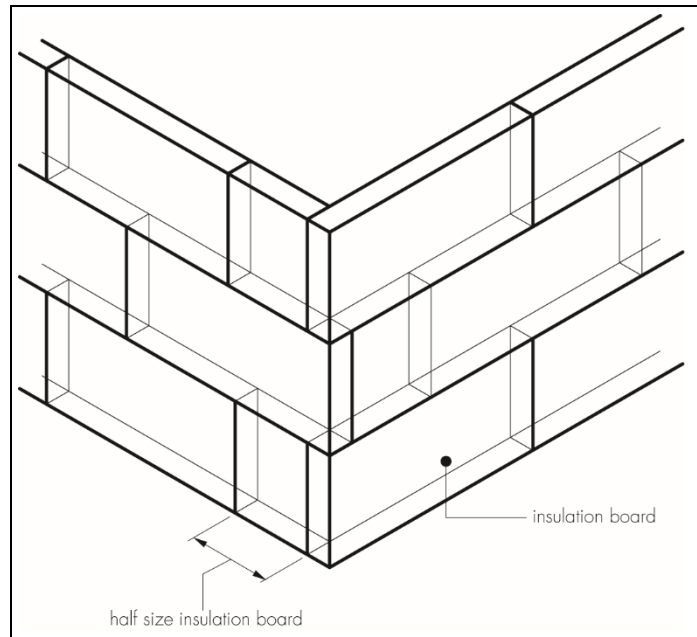

16.10 Holes are drilled through the insulation board into the substrate wall and supplementary mechanical fixings are applied, with two fixings per board over the entire wall (resulting in three fixings per square metre); additional fixings are applied at each corner of the insulation in the edge zone (at the corners of the building).

16.11 Around openings, additional fixings should be installed as determined by the system designer. The mechanical fixings are inserted and tapped firmly into place, securing the boards to the substrate.

16.12 To fit around details such as doors and windows, insulation boards may be cut with a sharp knife or a fine-tooth saw. If required, purpose-made window sills are fitted, designed to prevent water ingress and incorporate drips to shed water clear of the system.

16.13 Installation continues until the whole wall is completely covered including, where appropriate, the building soffits and eaves.

16.14 Window and door reveals should be insulated to minimise the effects of cold bridging. Where clearance is limited, strips of approved insulation should be installed to suit available margins and details.

16.15 Prior to the application of the render system, a bead of joint sealant is gun-applied at window and door frames, overhanging eaves, gas and electric meter boxes, and wall vents, or where the render abuts any other building material or surface.

16.16 All corners are fixed with mesh angles installed with adhesive mortar. Where appropriate, application-specific profiles are installed, to allow rainwater to drain away.

Movement joints

16.17 Generally, movement joints are not required in the system but, if such a joint is already incorporated in the substrate, a movement joint must be provided in the insulation system (see Figure 6).

Figure 6 Vertical movement joint

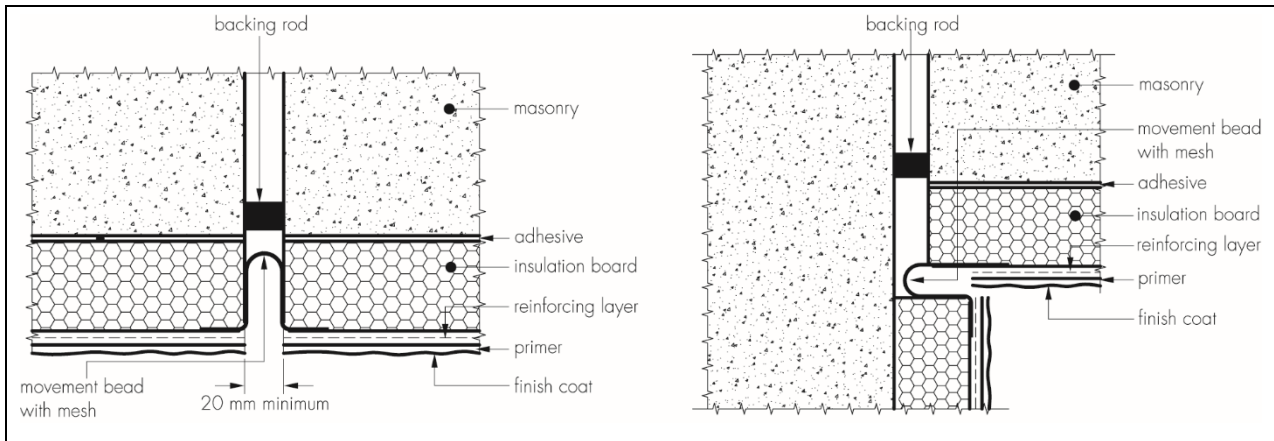

Application of basecoat and reinforcement mesh

16.18 The basecoat is prepared with the required amount of water (see section 1.1) then applied over the insulation boards using a stainless steel trowel, and floated with a Darby float to an approximate thickness of 3 mm. The reinforcement mesh (with its concave surface to the wall) is applied and immediately embedded into the basecoat by trowelling from the centre to the edge, and a light coat of basecoat applied whilst still wet to ensure the mesh is free of wrinkles. Additional basecoat is then applied as required, to ensure the mesh is completely covered and that the required minimum thickness is achieved, whilst ensuring that the mesh is placed in the top one third of basecoat.

16.19 The basecoat is applied progressively, working in one-metre sections in a vertical or horizontal direction.

16.20 Overlapping at all mesh joints should not be less than 100 mm.

16.21 In all cases, additional pieces of reinforcing mesh (200 by 300 mm) should be used diagonally at the corners of openings, as shown in Figure 7. For areas requiring extra resistance to impact, two mesh layers should be used in two stages.

16.22 The overall thickness of the reinforced basecoat must be greater than 3.5 mm. Once the whole wall is completed, the basecoat (with mesh) is left to dry thoroughly. The drying time will depend upon the conditions, but at least 72 hours should elapse before primer and finishing coats are applied.

Primer

16.23 The primer coat is roller-applied after the basecoat has dried, first making sure it is free from any irregularities (trowel-marks, exposed mesh, etc.).

Finishing coat

16.24 The render finishes are applied to the required thicknesses (1.5 to 3 mm as determined by the particle size – see section 1.3), using a stainless steel trowel and finished with a plastic trowel to create a textured finish. The drying time is dependent on conditions, but will typically be 24 hours in accordance with the Certificate holder's instructions. Stop beads are positioned vertically, eg at party wall positions where the adjoining property does not require treatment.

Figure 7 Additional reinforcement and fixings at opening

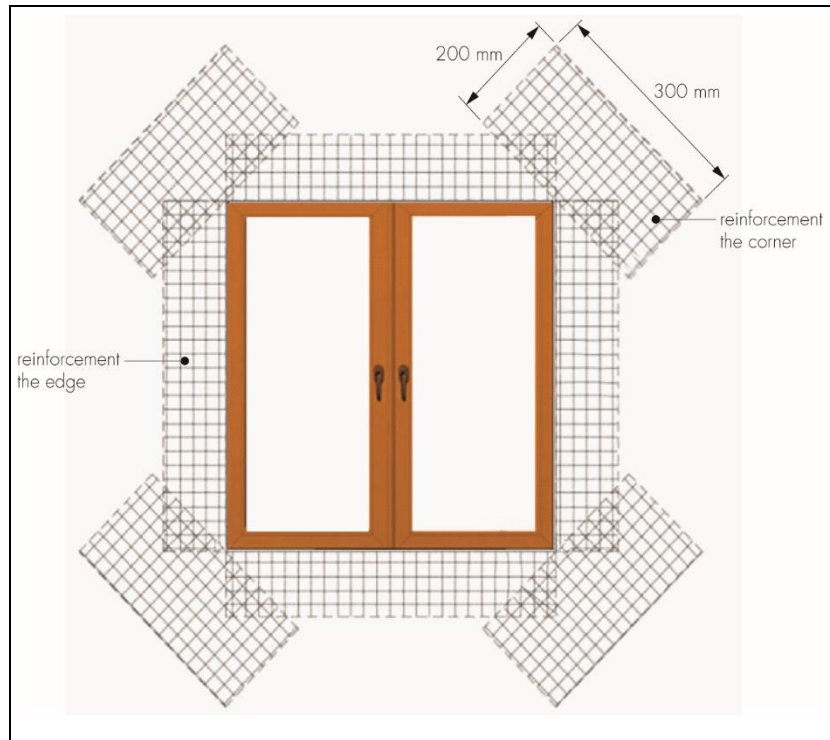

16.25 Continuous surfaces must be completed without a break, eg working to a wet edge. Care should be taken to prevent the basecoats and finish coats from either drying too rapidly or freezing.

16.26 At the tops of walls, the system should be protected by an adequate overhang (see Figure 8) or by an adequately sealed purpose-made flashing. Care should be taken in the detailing of the system around openings and projections (see Figures 9, 10 and 11).

Figure 8 Roof eaves details

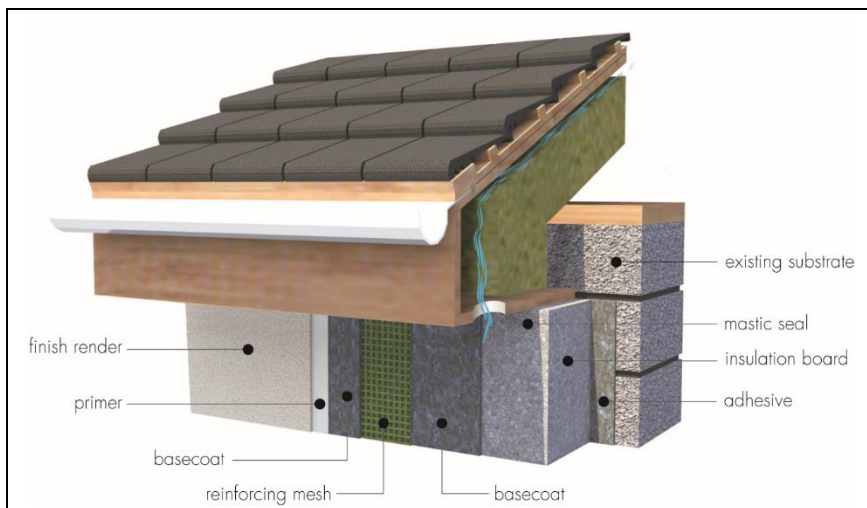

Figure 9 Window sill and reveal detail

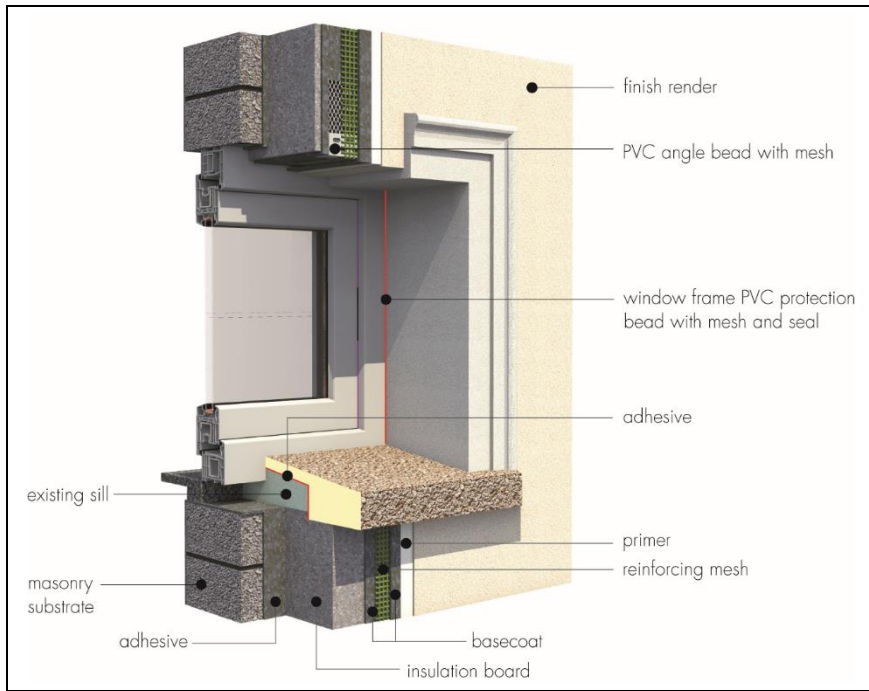

Figure 10 Window opening detail

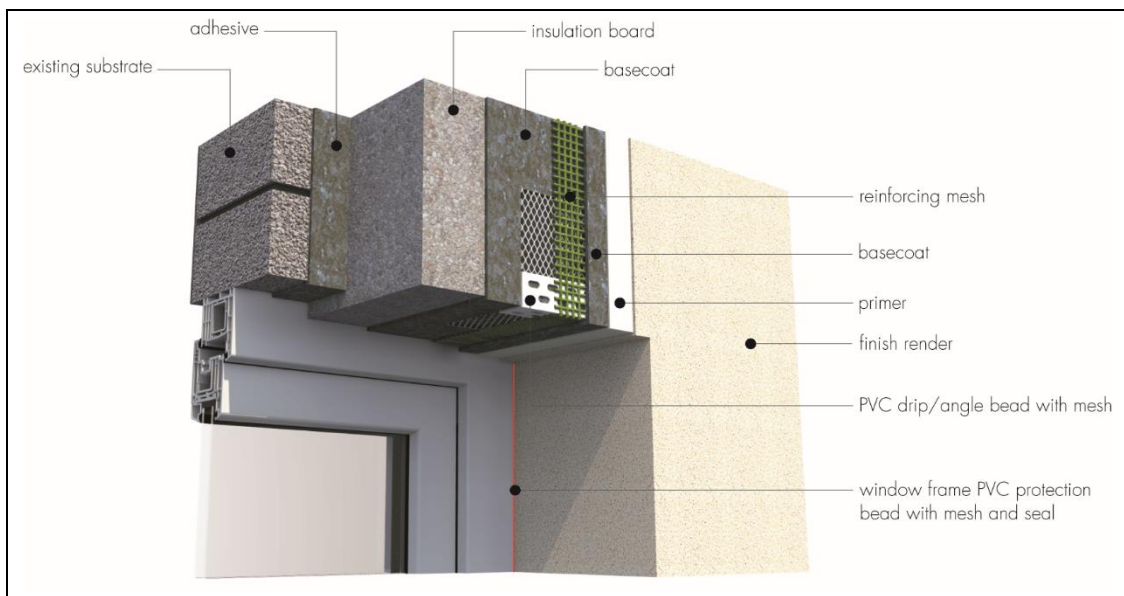
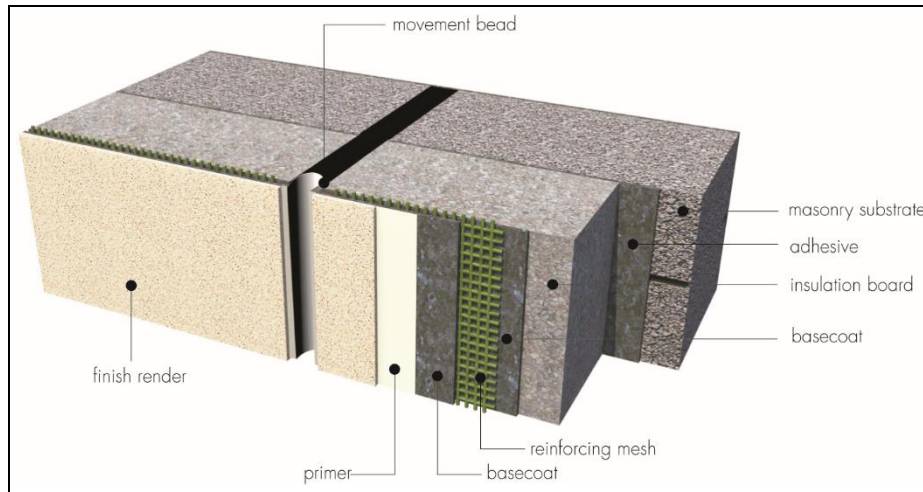

Figure 11 Movement joint detail



16.27 On completion of the installation, external fittings, eg rainwater goods, are securely fixed to timber grounds or extended fixings that have been built into the system during installation.

Technical Investigations

17 Test

Results of tests were assessed to determine:

- fire performance
- bond strength
- hygrothermal performance
- resistance to frost
- resistance to impact
- water vapour permeability.

18 Investigations

18.1 An examination was made of data relating to:

- reaction to fire
- thermal conductivity
- the risk of interstitial condensation.

18.2 The practicability of installation and the effectiveness of detailing techniques were examined.

18.3 The manufacturing process was evaluated, including the methods adopted for quality control, and details were obtained of the quality and composition of materials used.

Bibliography

BRE Report BR 135 : 2013 *Fire performance of external thermal insulation for walls of multistorey buildings*

BRE Report BR 262 : 2002 *Thermal insulation : avoiding risk*

BRE Report BR 443 : 2006 *Conventions for U-value calculations*

BS 5250 : 2011 + A1 : 2016 *Code of practice for control of condensation in buildings*

BS 8000-0 : 2014 *Workmanship on construction sites — Introduction and general principles*

BS 8000-2.2 : 1990 *Workmanship on building sites — Code of practice for concrete work — Sitework with in situ and precast concrete*

BS 8000-3 : 2001 *Workmanship on building sites — Code of practice for masonry*

BS EN 1990 : 2002 *Eurocode — Basis of structural design*

NA to BS EN 1990 : 2002 + A1 : 2005 *UK National Annex for Eurocode — Basis of structural design*

BS EN 1991-1-4 : 2005 *Eurocode 1 — Actions on structures — General actions — Wind actions*

NA to BS EN 1991-1-4 : 2005 *UK National Annex to Eurocode 1 — Actions on structures — General actions — Wind actions*

BS EN 1992-1-1 : 2004 + A1 : 2014 *Eurocode 2 — Design of concrete structures — General rules and rules for buildings*

NA to BS EN 1992-1-1 : 2004 + A1 : 2014 *UK National Annex to Eurocode 2 — Design of concrete structures — General rules and rules for buildings*

BS EN 1996-1-1 : 2005 + A1 : 2012 *Eurocode 6 — Design of masonry structures — General rules for reinforced and unreinforced masonry structures*

NA to BS EN 1996-1-1 : 2005 + A1 : 2012 *UK National Annex to Eurocode 6 — Design of masonry structures — General rules for reinforced and unreinforced masonry structures*

BS EN 1996-2 : 2006 *Eurocode 6 — Design of masonry structures — Design considerations, selection of materials and execution of masonry*

NA to BS EN 1996-2 : 2006 *UK National Annex to Eurocode 6 — Design of masonry structures — Design considerations, selection of materials and execution of masonry*

BS EN 13163 : 2012 + A2 : 2016 *Thermal insulation products for buildings — Factory made products of expanded polystyrene (EPS) — Specification*

BS EN 13501-1 : 2018 *Fire classification of construction products and building elements — Classification using test data from reaction to fire tests*

BS EN 13914-1 : 2016 *Design, preparation and application of external rendering and internal plastering — External rendering*

BS EN ISO 6946 : 2017 *Building components and building elements — Thermal resistance and thermal transmittance — Calculation method*

BS EN ISO 11600 : 2003 +A1 : 2011 *Building construction — Jointing products — Classification and requirements for sealants*

ETAG 004 : 2013 *Guideline for European Technical Approval of Plastic Anchors for fixing of External Thermal Composite Systems (ETICS) with Rendering.*

19 Conditions

19.1 This Certificate:

- relates only to the product/system that is named and described on the front page
- is issued only to the company, firm, organisation or person named on the front page – no other company, firm, organisation or person may hold or claim that this Certificate has been issued to them
- is valid only within the UK
- has to be read, considered and used as a whole document – it may be misleading and will be incomplete to be selective
- is copyright of the BBA
- is subject to English Law.

19.2 Publications, documents, specifications, legislation, regulations, standards and the like referenced in this Certificate are those that were current and/or deemed relevant by the BBA at the date of issue or reissue of this Certificate.

19.3 This Certificate will remain valid for an unlimited period provided that the product/system and its manufacture and/or fabrication, including all related and relevant parts and processes thereof:

- are maintained at or above the levels which have been assessed and found to be satisfactory by the BBA
- continue to be checked as and when deemed appropriate by the BBA under arrangements that it will determine
- are reviewed by the BBA as and when it considers appropriate.

19.4 The BBA has used due skill, care and diligence in preparing this Certificate, but no warranty is provided.

19.5 In issuing this Certificate the BBA is not responsible and is excluded from any liability to any company, firm, organisation or person, for any matters arising directly or indirectly from:

- the presence or absence of any patent, intellectual property or similar rights subsisting in the product/system or any other product/system
- the right of the Certificate holder to manufacture, supply, install, maintain or market the product/system
- actual installations of the product/system, including their nature, design, methods, performance, workmanship and maintenance
- any works and constructions in which the product/system is installed, including their nature, design, methods, performance, workmanship and maintenance
- any loss or damage, including personal injury, howsoever caused by the product/system, including its manufacture, supply, installation, use, maintenance and removal
- any claims by the manufacturer relating to CE marking.

19.6 Any information relating to the manufacture, supply, installation, use, maintenance and removal of this product/system which is contained or referred to in this Certificate is the minimum required to be met when the product/system is manufactured, supplied, installed, used, maintained and removed. It does not purport in any way to restate the requirements of the Health and Safety at Work etc. Act 1974, or of any other statutory, common law or other duty which may exist at the date of issue or reissue of this Certificate; nor is conformity with such information to be taken as satisfying the requirements of the 1974 Act or of any statutory, common law or other duty of care.